

ESCO
SCIENTIFIC



Labculture® • RELIANT G4

Class II Type A2 Biological Safety Cabinets

*The Most Advanced Energy-efficient, Safe,
and Ergonomic Biosafety Cabinet in the World*



LABCULTURE® RELIANT G4 (LR2 G4) CLASS II TYPE A2 BIOSAFETY



Zero Volt Relay Contact

- Zero Volt Relay Contact to turn ON/OFF exhaust blower and signal the building alarm

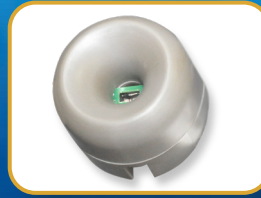

Airflow Sensor

- Monitors real-time airflow for safety
- Alert the user if airflow is insufficient



Rocker Switches and Pressure Gauge

- New and improved controller interface
- Easy to use switches and displays filter loading status
- Manually adjustable UV timer



Single Piece Wall

- Easy to reach service fixtures and electrical outlets on sidewalls
- Large radius corners for easy cleaning



User-friendly Work Tray

- Largest useable area in the market
- Recessed to contain spillage
- Sloped perimeter for easy cleaning
- Large, easy to clean tray handle



Raised Arm Rest

- Prevent grille blocking
- Comfortable working posture
- Durable stainless steel construction



Ergonomic Work Zone

- 10° angle to optimize user comfort, reduce glare, and maximize reach into the work area
- Brightly illuminated with >1200 lux (111 ft. cd)
- Airtight seal port for cable/tube exit protected by a negative pressure side wall



Esco Labculture® RELIANT G4 Class II Type A2 Biosafety Cabinet
Available in 3 feet, 4 feet, 5 feet, and 6 feet models.

CABINET, FEATURING ADVANCED MICROPROCESSOR CONTROLLER

Energy-efficient DC ECM Blower

- The leading energy efficient Class II Type A2 Biosafety Cabinet in the world with 70% energy savings compared to AC motor
- Stable airflow despite building voltage fluctuations and filter loading
- Standby mode to further reduce power consumption by 80%

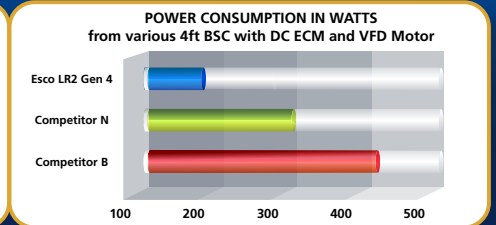
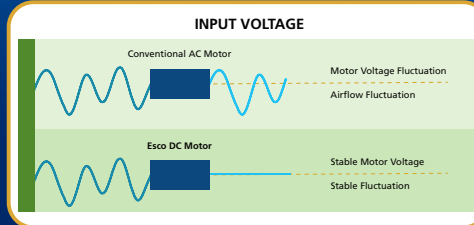

Advance Filtration System

- 10x Filtration efficiency of HEPA filter
- Creates ISO Class 3 work zone instead of Industry-standard ISO Class 5
- Same 10 years filter life and replacement cost as HEPA filters



User Modified Pass-Through / Cable Port

- 3" Port with 1/4" hole on rubber membrane inside
- NSF-approved. Surrounded by negative pressure
- Allows cables and tubes to exit with fully closed sash



Removable Paper Catch

- Prevent objects from being pulled into blower plenum
- Removable for easy cleaning
- Optional pre-filter can be fitted



Tray Support Beams

- Support work tray evenly for less vibration
- Cleaning holder to easily wipe the drain pan

ISOCIDE™ Powder Coat

- Silver-ion impregnated powder coat
- Inhibits microbial growth to improve safety
- Prevents the plenum from becoming biohazard landfill

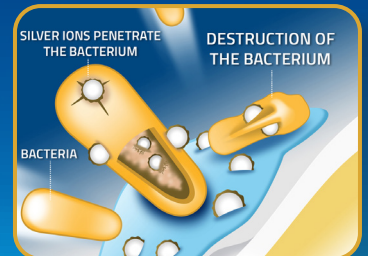

Certification

	Performance	Air Quality	Filtration	Electrical Safety
Standards Compliance	NSF / ANSI 49, USA	ISO 14644.1, Class 3, Worldwide US Fed Std 209E, Class 1 USA JIS B9920, Class 3, Japan	EN-1822 (H14), Europe IEST-RP-CC001, USA	UL 61010-1 3rd Ed, USA CSA22.2, No.1010-192, Canada

Dynamic Chamber™

- Blower plenum and side walls are surrounded by negative pressure
- Prevent contaminants from escaping outside

- Positive Pressure
- Negative Pressure



Cabinet Filtration System

- Ambient air is pulled through front grille to create inflow, without going into the work surface. Inflow is joined by half of the downflow, to create front air curtain that is fine-tuned to create a large performance envelope. The combined air stream travels through the back air column towards the blower.
- Approximately 1/3 of the air in the common plenum is exhausted through the ULPA filter to the room. The remaining 2/3 of the air is passed through the downflow ULPA filter and into the work area as a vertical laminar flow air to create ISO Class 3 work surface and prevents cross contamination.
- Near the work surface, the downflow splits. About half goes to the front grille, and half goes to the rear grille. A small portion enters the side capture zones to prevent dead air corners (small blue arrows).
- The design was optimized to give large performance envelope, that provides operator and product protection at wide Inflow and Downflow variation from the Nominal point.

The Performance Envelope Concept

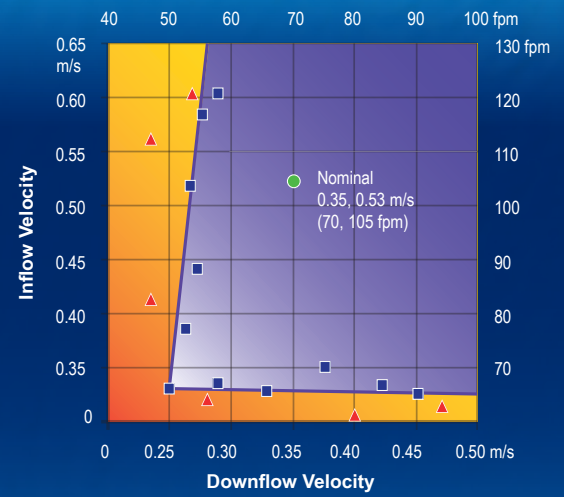

Dynamic air barrier, where inflow and downflow converge
Side capture zones

- ULPA-filtered air
- Unfiltered / potentially contaminated air
- Room air / Inflow air

Engineering Drawing

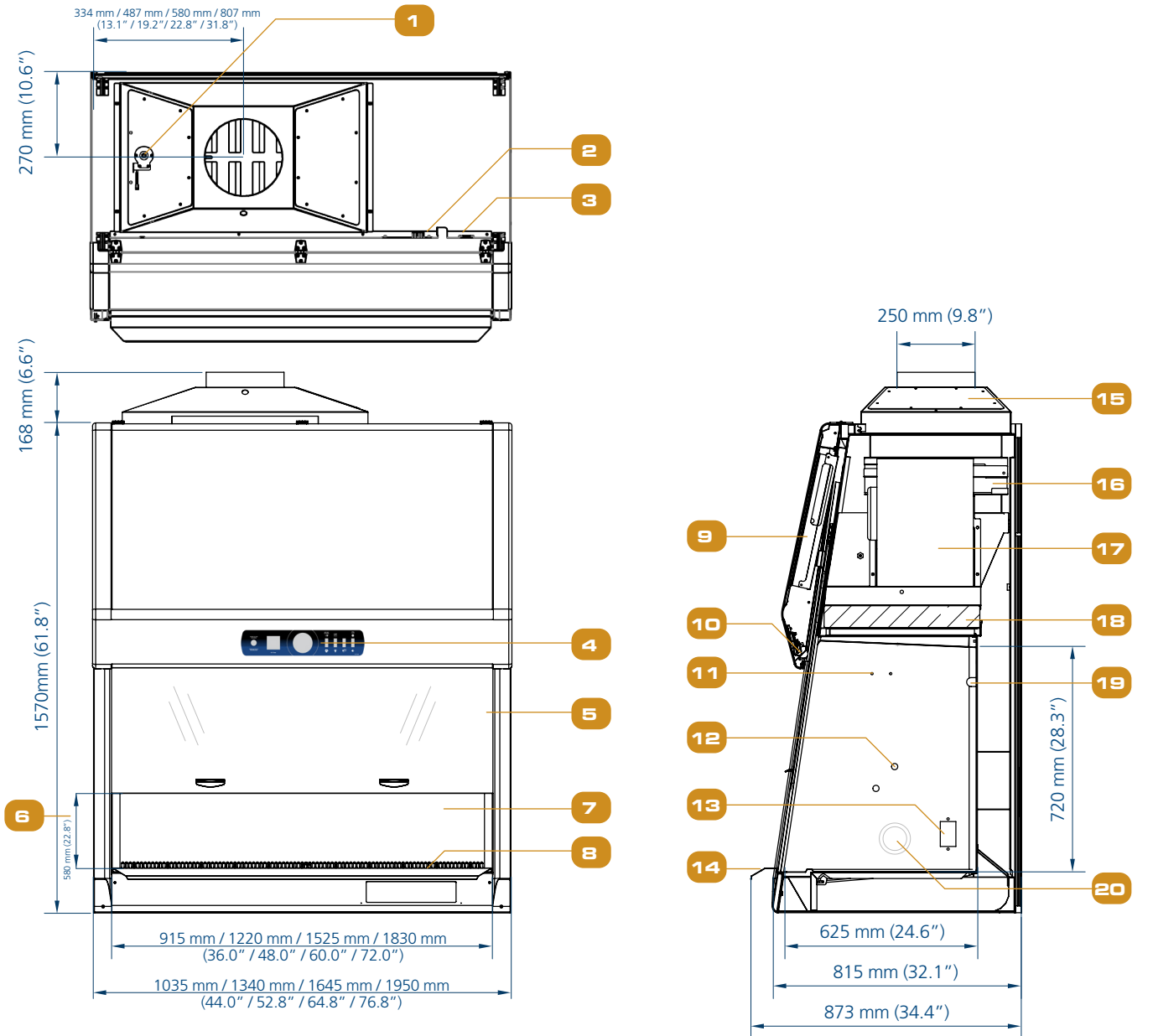

1. Exhaust Airflow Sensor
2. Zero Volt Relay Contact
3. Power Inlet
4. Simple Switches Controller
5. Angled Sash Glass Window

6. Max. Sash Opening
7. Single-piece Stainless Steel Back Wall
8. Single-piece Stainless Steel Work Tray
9. Electrical Panel
10. LED Lamp

11. IV Bar Retrofit Kit Provision
12. Service Fixture Retrofit Kit Provision
13. Electrical Outlet Provision
14. Stainless Steel Arm Rest
15. Exhaust Collar (optional)

16. Exhaust Filter
17. DC-ECM Blower
18. Downflow Filter
19. UV Lamp Provision
20. Cable Port (right side only)

TECHNICAL SPECIFICATIONS

Labculture® Class II		Stainless Steel Side Walls	110-130 VAC, 50/60 Hz	LR2-359-G4 8" 2011461	LR2-459-G4 8" 2011463	LR2-559-G4 8" 2011465	LR2-659-G4 8" 2011467	
			220-240 VAC, 50/60 Hz	LR2-359-G4 10" 2011499	LR2-459-G4 10" 2011501	LR2-559-G4 10" 2011503	LR2-659-G4 10" 2011505	
Nominal Size			0.9 meter (3')	1.2 meter (4')	1.5 meter (5')	1.8 meter (6')		
External Dimensions (W x D x H)		Without Arm Rest	1035 x 815 x 1570 mm (40.8" x 32.1" x 61.8")	1340 x 815 x 1570 mm (52.8" x 32.1" x 61.8")	1645 x 815 x 1570 mm (64.8" x 32.1" x 61.8")	1950 x 815 x 1570 mm (76.8" x 32.1" x 61.8")		
		With Arm Rest	1035 x 873 x 1570 mm (40.8" x 34.4" x 61.8")	1340 x 873 x 1570 mm (52.8" x 34.4" x 61.8")	1645 x 873 x 1570 mm (64.8" x 34.4" x 61.8")	1950 x 873 x 1570 mm (76.8" x 34.4" x 61.8")		
Internal Dimensions (W x D x H)			915 x 625 x 720 mm (36.0" x 24.6" x 28.3")	1220 x 625 x 720 mm (48.0" x 24.6" x 28.3")	1525 x 625 x 720 mm (60.0" x 24.6" x 28.3")	1830 x 625 x 720 mm (72.0" x 24.6" x 28.3")		
Usable Work Area			0.47 m ² (5.0 sq.ft.)	0.63 m ² (6.8 sq.ft.)	0.80 m ² (8.5 sq.ft.)	0.96 m ² (10.3 sq.ft.)		
Sash opening		Available in 203 mm (8"), 254 mm (10"), and 305 mm (12")						
Maximum Sash Opening		570 mm (22.5")						
Average Airflow Velocity		Inflow	203 mm (8")	0.53 m/s (105 fpm)	0.53 m/s (105 fpm)	0.53 m/s (105 fpm)	0.53 m/s (105 fpm)	
			254 mm (10")	0.53 m/s (105 fpm)	0.53 m/s (105 fpm)	0.53 m/s (105 fpm)	0.53 m/s (105 fpm)	
			305 mm (12")	0.53 m/s (105 fpm)	0.53 m/s (105 fpm)	0.53 m/s (105 fpm)	0.53 m/s (105 fpm)	
		Downflow	203 mm (8")	0.30 m/s (60 fpm)	0.30 m/s (60 fpm)	0.30 m/s (60 fpm)	0.30 m/s (60 fpm)	
			254 mm (10")	0.33 m/s (65 fpm)	0.30 m/s (60 fpm)	0.33 m/s (65 fpm)	0.30 m/s (60 fpm)	
			305 mm (12")	0.35 m/s (70 fpm)	0.30 m/s (60 fpm)	0.35 m/s (70 fpm)	0.35 m/s (70 fpm)	
Airflow Volume		Inflow	203 mm (8")	356 m ³ /h (210 cfm)	473 m ³ /h (280 cfm)	593 m ³ /h (350 cfm)	709 m ³ /h (420 cfm)	
			254 mm (10")	446 m ³ /h (263 cfm)	591 m ³ /h (350 cfm)	741 m ³ /h (438 cfm)	887 m ³ /h (525 cfm)	
			305 mm (12")	535 m ³ /h (315 cfm)	710 m ³ /h (420 cfm)	890 m ³ /h (525 cfm)	1065 m ³ /h (629 cfm)	
		Downflow	203 mm (8")	581 m ³ /h (345 cfm)	771 m ³ /h (461 cfm)	967 m ³ /h (567 cfm)	1156 m ³ /h (691 cfm)	
			254 mm (10")	639 m ³ /h (374 cfm)	848 m ³ /h (499 cfm)	1063 m ³ /h (624 cfm)	1272 m ³ /h (748 cfm)	
			305 mm (12")	678 m ³ /h (397 cfm)	771 m ³ /h (461 cfm)	1128 m ³ /h (662 cfm)	1349 m ³ /h (794 cfm)	
		Exhaust	203 mm (8")	356 m ³ /h (210 cfm)	473 m ³ /h (280 cfm)	593 m ³ /h (350 cfm)	709 m ³ /h (420 cfm)	
			254 mm (10")	446 m ³ /h (263 cfm)	591 m ³ /h (350 cfm)	741 m ³ /h (438 cfm)	887 m ³ /h (525 cfm)	
			305 mm (12")	535 m ³ /h (315 cfm)	710 m ³ /h (420 cfm)	890 m ³ /h (525 cfm)	1065 m ³ /h (630 cfm)	
ULPA Filter Typical Efficiency		≥99.999% for particle size between 0.1 to 0.3 microns						
Sound Emission (dBA)*		NSF / ANSI 49	203 mm (8")	57	57	60	63	
			254 mm (10")	60	59	63	63.3	
			305 mm (12")	62	60	65	65.9	
LED Lamp Light Intensity		> 1200 lux (111 ft. cd)						
Cabinet Construction		Main body	Electro-galvanized steel with white oven-baked epoxy-polyester Isocide™ antimicrobial powder-coated finish, 1.5 mm (0.06") / 16 gauge thick					
		Work Zone	Stainless steel type 304 with no.4 finish, 1.5 mm (0.06") / 16 gauge thick					
		Sash Window	6 mm UV-absorbing Tempered Glass					
Electrical**		Nominal power (Watt) (8)	203 mm (8")	160	190	350	366	
			254 mm (10")	195	201	374	420	
			305 mm (12")	228	236	455	550	
		Nominal power (Watt) (9)	203 mm (8")	163	193	355	372	
			254 mm (10")	203	205	380	431	
			305 mm (12")	232	240	460	537	
		Heat Load (BTU/hr) (8)	203 mm (8")	546	648	1194	1249	
			254 mm (10")	665	686	1276	1433	
			305 mm (12")	778	805	1553	1877	
		Heat Load (BTU/hr) (9)	203 mm (8")	556	659	1211	1269	
			254 mm (10")	693	699	1297	1471	
			305 mm (12")	792	819	1570	1832	
		Full Load Amps (8) exclude 5A EO	203 mm (8")	6 A		10 A		
			254 mm (10")	6 A		10 A		
			305 mm (12")	6 A		10 A		
Optional Outlets FLA		5A						
Full Load Amps (9) exclude 5A EO	203 mm (8")	10 A		16 A				
	254 mm (10")	10 A		16 A				
	305 mm (12")	10 A		16 A				
Optional Outlets FLA		5A						
Net Weight			243 Kg (536 lbs)	287 Kg (633 lbs)	381 Kg (840 lbs)	400 kg (882 lbs)		
Shipping Weight			292 Kg (644 lbs)	350 Kg (772 lbs)	439 Kg (968 lbs)	506 kg (1116 lbs)		
Shipping Dimensions, Maximum (W x D x H)			1185 x 890 x 1900 mm (46.7" x 35.0" x 74.8")	1490 x 890 x 1900 mm (58.7" x 35.0" x 74.8")	1795 x 890 x 1900 mm (70.7" x 35.0" x 74.8")	2100 x 890 x 1900 mm (82.7" x 35.0" x 74.8")		
Shipping Volume Dimensions (W x D x H)			2.00 m ³ (cu.ft.)	2.5 m ³ (cu.ft.)	3.00 m ³ (cu.ft.)	3.6 m ³ (cu.ft.)		

Disclaimer: Technical Specifications may be subjected to further changes without further notice.

*Noise reading in open field condition / anechoic chamber. Noise reading in normal room varies by room size, layout, and background noise, but may reach roughly 3-4 dBA above these values.

**Electrical power consumption is an measurement of new unit with clean filter operated within nominal setpoint. Result per unit may vary.

Options and Accessories

Anti-blowback Valve 10 inches	304 Stainless Steel	ABBV-10S 5170354			
Exhaust Collar		ECO-F-LA2-3-G4 5171097	ECO-F-LA2-4-G4 5171098	ECO-F-LA2-5-G4 5171099	ECO-F-LA2-6-G4 5171100
UV Lamp		UV-15A 5170251	UV-30A 5170255		
IV Bar		IV-910 5170499	IV-1215 5170231	IV-1520 5170500	IV-1825 5170501
Electrical Outlet	Direct Mounted	EO-HC 5170035			
	GFCI	EO-GFCI 5170071			
Service Fixtures	EU SF-Gas-20 mm and Solenoid Valve	SF-1G20 5170410			
	EU SF-Vacuum-20 mm	SF-1V20 5170457			
	EU SF-Air-20 mm	SF-1A20 5170502			
	EU SF-Nitrogen-20 mm	SF-1N20 5170503			
	EU SF-Water-20 mm	SF-1W20 5170458			
	US SF-Universal-20 mm	SF-2U22 5170504			
	Copper Piping for SF	CU-Pipe 5170026			
Support Stand		STA-3A0 5131340	STA-4A0 5131341	STA-5A0 5131427	STA-6A0 5131389
Pipette Storage Shelf		5260327			
Arm Rest Padding		MEWREST 5170127			
Foot Rest		FT-REST 5170492			
Laboratory Chair		ME-LD-AR360 1150006			
IQOQ Protocol		9010179			



ABBV_



UV_A-L

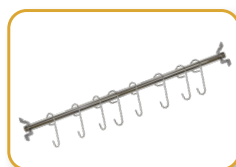

IV_



EO-H_



EO-GFCI



SF-1_



SF-2U_



STA_



Pipette Storage Shelf



MEWREST



FT-REST



ME-LD-AR360



IQOQ

ESCO

LIFESCIENCES GROUP

Improving Lives through Science

ESCO SCIENTIFIC



- Animal Research Workstation
- Biological Safety Cabinet
- CO₂ Incubator
- Ducted Fume Hood
- Ductless Fume Hood
- Filtered Storage Cabinet
- Laboratory Centrifuge
- Laboratory Oven and Incubator
- Laboratory Refrigerator and Freezer
- Laboratory Shaker
- Laminar Flow Cabinet
- PCR Cabinet
- Powder Weighing Balance Enclosure
- Thermal Cycler
- Ultra-low Temperature Freezer

ESCO MEDICAL



- Time-Lapse Incubator
- Benchtop Incubator
- ART Workstation
- CO₂ Incubator
- Anti-Vibration Table
- Gas Analyser

ESCO Healthcare

"Discovery to Delivery"



ESCO
PHARMA

ESCO
TaPestle

ESCO
VACCIXCELL

Pharmaceutical Manufacturing, Pharmacy Compounding,
and Bioprocessing Tools

ESCO ASTER



CRDMO Services

ESCO

ESCO LIFESCIENCES GROUP
42 LOCATIONS IN 21 COUNTRIES ALL OVER THE WORLD

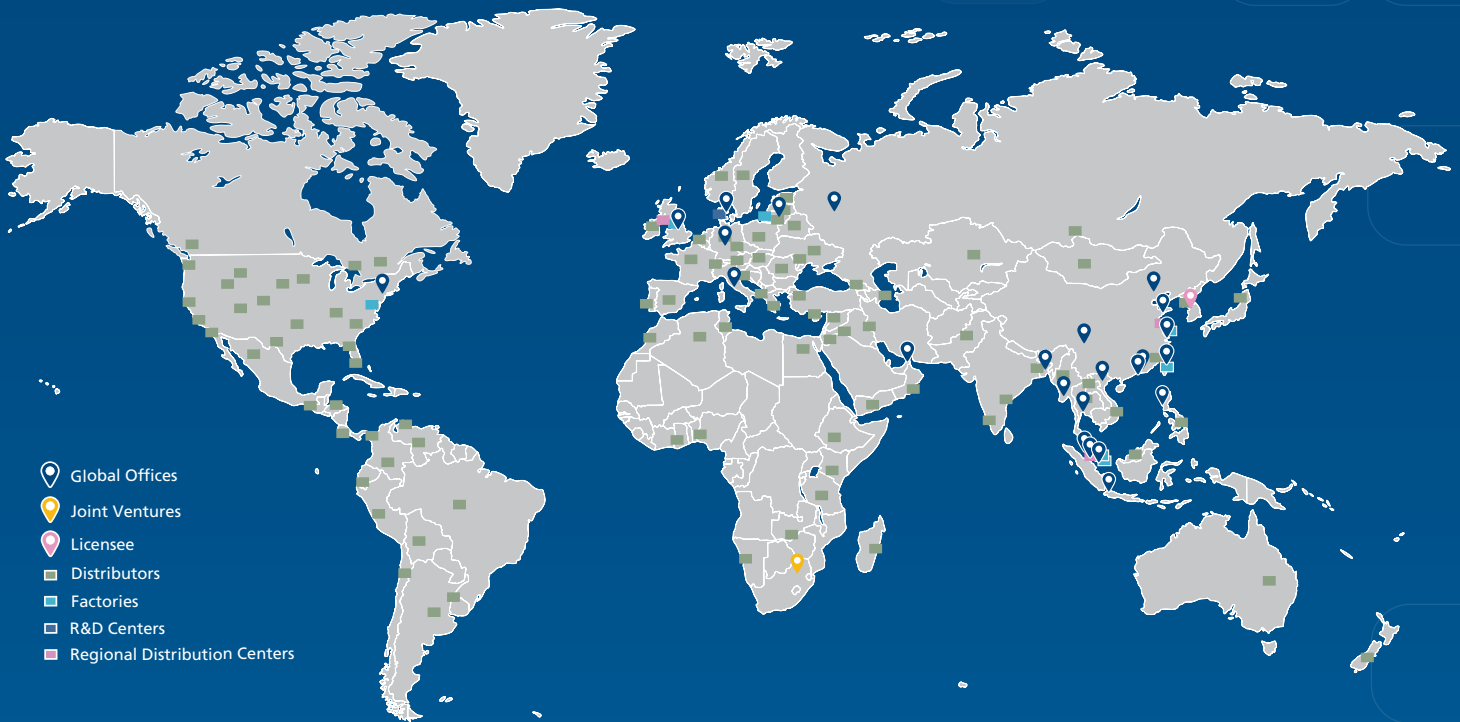

- 📍 Global Offices
- 📍 Joint Ventures
- 📍 Licensee
- 📍 Distributors
- 📍 Factories
- 📍 R&D Centers
- 📍 Regional Distribution Centers

*Follow us on social media, download our apps,
and scan the QR code for more info.*



@EscoLifesciences



@EscoLifesciences



@EscoLifesci



@Esco



@EscoLifesciences



@EscoLifesciences



Esco Lifesciences



Esco Lifesciences

ESCO[®]

LIFESCIENCES GROUP

Esco Micro Pte. Ltd. • 19 Changi South Street 1 • Singapore 486779
Tel +65 6542 0833 • mail@escolifesciences.com
www.escolifesciences.com

Esco Technologies, Inc. • 903 Sheehy Drive, Suite F, Horsham, PA 19044, USA
Tel: +1 215-441-9661 • eti.admin@escolifesciences.com

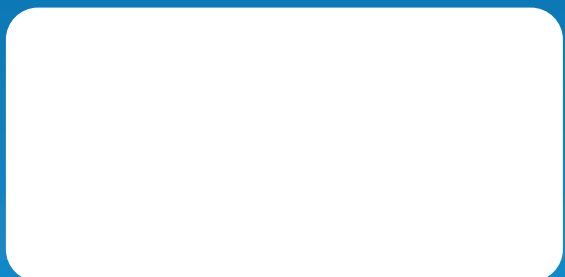

Esco Lifesciences Group Offices: Bangladesh | China | Denmark | Germany | Hong Kong | India | Indonesia | Italy | Japan | Lithuania | Malaysia | Myanmar | Philippines | Russia | Singapore | South Africa | South Korea | Taiwan | Thailand | UAE | UK | USA | Vietnam